



Cox
Turbine Flow Meters

Turbine Flow Meters

Precision Series LoFlo Meters

DESCRIPTION

Cox Precision LoFlo Meters are designed to provide exceptional repeatability and speed of response when measuring very low flow rates. The LoFlo meter features a cantilever axial helical rotor design and robust ceramic ball bearings. The meter design is suited for more rugged applications, where other meters are susceptible to damage derived from vibrations or shock. Additionally, the stainless steel square body facilitates 5000 psi line pressure and provides flat wrench surfaces to assist in installation and removal.

APPLICATIONS

The Cox LoFlo meter thrives in—but is not limited to—applications such as:

- Attitude and position control rocket engines
- Compatibility with exotic fuels and oxidizers, such as:
 - N2O4
 - UDMH
 - MMH
 - Hydrazine
 - Refrigerant
- Blending applications
- Leak detection
- Fuel monitoring
- Batching

CALIBRATIONS

Calibrations are accomplished by using various blends of solvent and oil to simulate actual fluid conditions. For varying process temperature conditions, multiple viscosity calibrations are used to develop a universal viscosity curve. UVC calibrations enable a flow computer to track temperature and compensate for fluid viscosity. Flow Dynamics tailors calibrations to replicate process conditions, so the meter is characterized to provide the best attainable accuracy.

Calibrations are performed by our Flow Dynamics NVLAP (Lab Code 200668-0) accredited calibration facility located in Racine WI, which uses primary standard calibrators, offering uncertainties of ± 0.05 percent of reading with ± 0.02 percent repeatability. Users can be assured that Cox Precision Meters come with a best-in-class calibration traceable to NIST standards.



NVLAP accreditation applies only to the Badger Meter Flow Dynamics calibration Lab, located in Racine, WI



Badger Meter

CXX-DS-00212-EN-07 (July 2018)



OPERATION

As a fluid passes through the meter, the velocity of the fluid creates rotational energy on the rotor. The rotor blades, passing through a magnetic or radio frequency field, generate pulses proportional to flow. Each pulse is transmitted to the meter electronics, where it amplifies the pulse output.

The LoFlo models are inherently nonlinear, due to their small blade geometry, but are repeatable within ± 0.25 percent of reading. For more complex flow measurement applications, a flow processor is recommended to linearize and temperature compensate the flow meter output. Because each application differs in the type of fluid and operating temperature range, the actual linearity and temperature compensation results will vary. Cox's experienced application engineers can recommend the flow meter model and calibration parameters to obtain the best accuracy possible. Temperature fluid viscosity compensation, to include the meter bore diameter using thermal expansion coefficients, are achieved by means of Strouhal-Roshko equations.

Product Data Sheet

SPECIFICATIONS

Performance	Repeatability	± 0.25% of reading
	Calibrator uncertainty	± 0.05% of reading
	Frequency output	1500 ... 1800 Hz (Maximum)
	Response time	20...30 ms or better (at 1.2 cSt)
	Pressure rating	5000 psi (4 times less than burst)
Materials of Construction	Body	316 stainless steel
	Shafts	316 stainless steel
	Rotors	17-4 PH stainless steel
	Bearing	Ceramic ball

Flow Range

Size	Flow Range (10:1 flow Ratio)		Extended Flow Range*		Maximum Frequency (Hz)	ΔP ** PSID (kg/cm ²)
	gpm (lpm)	lb/hr (kg/hr)	gpm (lpm)	lb/hr (kg/hr)		
6-000	0.007...0.075 (0.027 ... 0.284)	2.850...28.50 (1.290 ... 12.90)	0.006...0.075 (0.024 ... 0.284)	2.200...28.50 (0.998 ... 12.90)	1800	20.0 (1.4)
6-00	0.012...0.125 (0.045...0.473)	4.750...47.50 (2.150...21.50)	0.009...0.125 (0.034...0.473)	3.400...47.50 (1.540...21.50)	1800	12.0 (0.84)
6-0	0.025...0.250 (0.095...0.946)	9.500...95.00 (4.310...43.10)	0.014...0.250 (0.053...0.946)	5.400...95.00 (2.450...43.10)	1800	4.50 (0.32)
6-1	0.050...0.500 (0.189...1.890)	19.00...190.0 (8.620...86.20)	0.023...0.500 (0.087...1.890)	8.800...190.0 (3.990...86.20)	1500	4.00 (0.28)
6-2	0.075...0.750 (0.284...2.840)	28.50...285.0 (12.90...129.0)	0.037...0.750 (0.140...2.890)	13.20...285.0 (5.990...129.0)	1500	4.50 (0.32)
6-3	0.125...1.250 (0.473...4.730)	47.50...475.0 (21.50...215.0)	0.060...1.250 (0.227...4.730)	22.00...475.0 (9.980...215.0)	1350	7.00 (0.49)

* With use of RF (Carrier) Pickoff

**Pressure drop is based on liquid with a specific gravity of 0.77, at maximum frequency

DIMENSIONS

The dimension from the center of bore to top of pickoff represents the most common pickoff types. Length may vary depending on pickoff choice. Consult factory for details.

NOTE: Dimensions below are shown in inches.

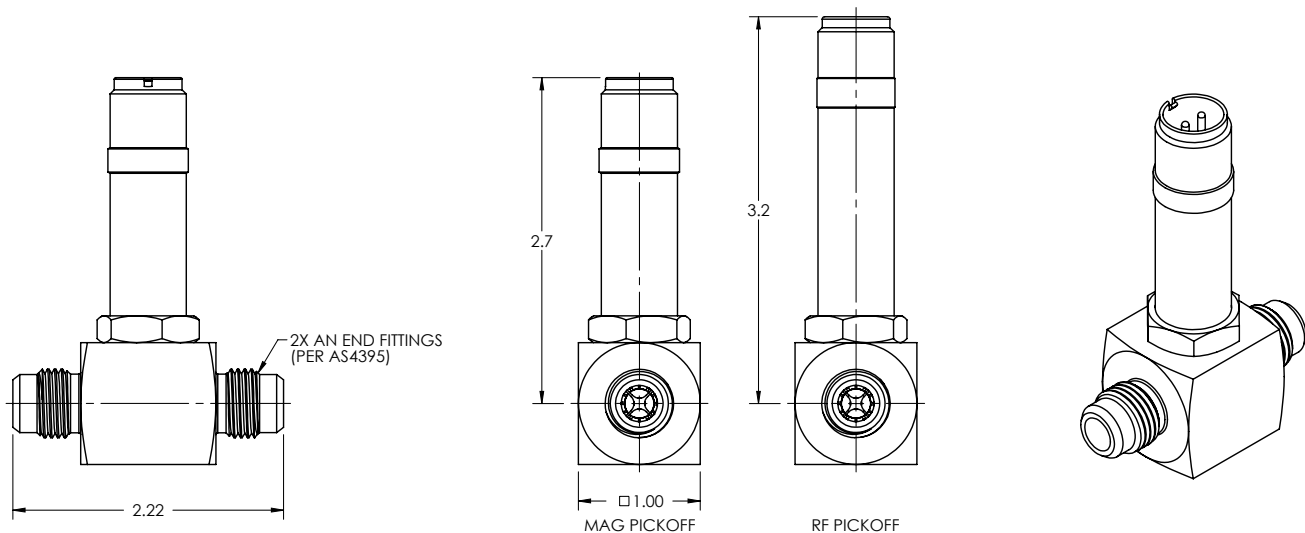

METER MODEL NUMBER

Cox Precision LoFlo Turbine Flow Meters



Model

Precision Turbine LoFlo CLF

Meter Size

- 6-000 (3/8" AN Fitting) A6
- 6-00 (3/8" AN Fitting) B6
- 6-0 (3/8" AN Fitting) C6
- 6-1 (3/8" AN Fitting) D6
- 6-2 (3/8" AN Fitting) E6
- 6-3 (3/8" AN Fitting) F6

End Fitting Type

37° MS Flare AN

Bearing

Hybrid Ceramic Ball Bearing, Water/Hydrocarbon Service C

Pickoff

- RF | 2-Pin MS | -250...400° F | C01
- RF | 2-FL | -250...400° F | C02
- RF | FL | -330...450° F | RTD C03
- RF | 3-Pin MS | -40...185° F | Signal Conditioner, IS C04
- RF | 3-Pin MS | -40...185° F | Amp, ATEX, IS C05
- RF | 3-Pin MS | -40...248° F | Amp C06
- RF | 6-Pin MS | -49...284° F | Amp, RTD C07
- RF | 6-Pin Micro DIN | -49...284° F | Amp, RTD C08
- RF | 3-FL | -40...248° F | Amp C09
- MAG | 2-Pin MS | -450...450° F | 45-55 G M01

Specials

3-Digit Special Code (Leave blank for non-custom orders.) XXX

Control. Manage. Optimize.

COX INSTRUMENTS is a registered trademark of Badger Meter, Inc. Other trademarks appearing in this document are the property of their respective entities. Due to continuous research, product improvements and enhancements, Badger Meter reserves the right to change product or system specifications without notice, except to the extent an outstanding contractual obligation exists. © 2018 Badger Meter, Inc. All rights reserved.

www.badgermeter.com

The Americas | Badger Meter | 4545 West Brown Deer Rd | PO Box 245036 | Milwaukee, WI 53224-9536 | 800-876-3837 | 414-355-0400
México | Badger Meter de las Americas, S.A. de C.V. | Pedro Luis Ogazón N°32 | Esq. Angelina N°24 | Colonia Guadalupe Inn | CP 01050 | México, DF | México | +52-55-5662-0882
Europe, Eastern Europe Branch Office (for Poland, Latvia, Lithuania, Estonia, Ukraine, Belarus) | Badger Meter Europe | ul. Korfantego 6 | 44-193 Knurów | Poland | +48-32-236-8787
Europe, Middle East and Africa | Badger Meter Europa GmbH | Nurtinger Str 76 | 72639 Neuffen | Germany | +49-7025-9208-0
Europe, Middle East Branch Office | Badger Meter Europe | PO Box 341442 | Dubai Silicon Oasis, Head Quarter Building, Wing C, Office #C209 | Dubai / UAE | +971-4-371 2503
Slovakia | Badger Meter Slovakia s.r.o. | Racianska 109/B | 831 02 Bratislava, Slovakia | +421-2-44 63 83 01
Asia Pacific | Badger Meter | 80 Marine Parade Rd | 21-06 Parkway Parade | Singapore 449269 | +65-63464836
China | Badger Meter | 7-1202 | 99 Hangzhong Road | Minhang District | Shanghai | China 201101 | +86-21-5763 5412
Switzerland | Badger Meter Swiss AG | Mittelholzerstrasse 8 | 3006 Bern | Switzerland | +41-31-932 01 11